

PEGASUS II 10-40

PEGASUS II 10-40kVA

10-20kVA, 3/1-phase, cos phi 0,9
10-40kVA, 3/3-phase, cos phi 0,9

NEU / NEW

On-line double conversion 10, 15, 20, 30, 40kVA

The PEGASUS II is EFFEKTA®'s new on-line double conversion UPS with either 1 - or 3-phase output.

The system can be configured to parallel redundancy. There can be up to 8 units in parallel. Thus, the reliability is increased.

The PEGASUS II UPS series is fabricated in modular design and offers extensive self-diagnostic capabilities for each power module. This simplifies the maintenance of the Pegasus II and reduces the time required for this effort.

The usage of IGBT rectifiers reduces the distortion of dependent mains. The current drain is almost ideally sinusoidal.

Benefits:

- Huge input voltage range
- Parallel option for up to 8 units
- Power factor >0.99
- Frequency converter mode
50Hz > 60Hz or 60Hz > 50Hz
- Eco Mode (efficiency 95-98%)
- Low THD(i) even at partial load



Features:

- UPS classification VFI-SS111 (IEC 62040-3)
- On-line double conversion
- PFC rectifier with IGBT technology
- Modular technology
- Input either 1 - or 3-phase (up to 20 kVA)
- Modules with progressive self diagnostics
- High efficiency
- Sine wave output
- Digital signaling processor
- Clearly arranged LCD display
- Low weight
- RS232 and expandability for various interfaces (SNMP, Relays, RS485/Modbus)
- 24 month's warranty

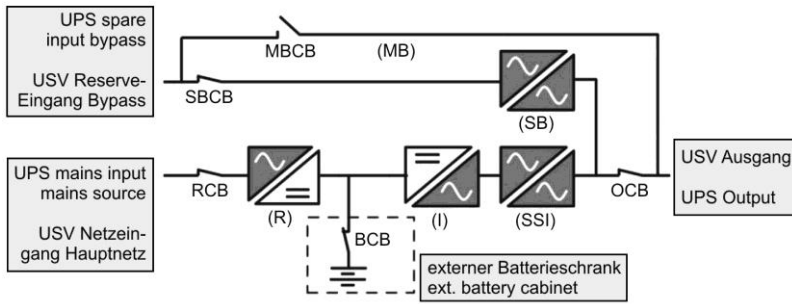

block diagram



UPS electronics (modular construction / power modules)

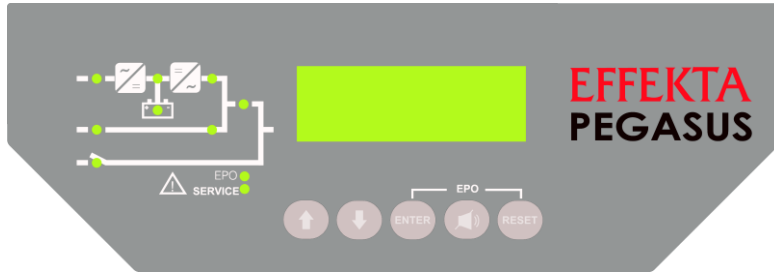

control panel

Specifications

Model		PEGASUS II 10kVA 31/33	PEGASUS II 15kVA 31/33	PEGASUS II 20kVA 31/33	PEGASUS II 30kVA 33	PEGASUS II 40kVA 33	
Power		10kVA / 9kW	15kVA / 13.5kW	20kVA / 18kW	30kVA / 27kW	20kVA / 36kW	
Efficiency (AC-AC) - % (ECO-mode)		>98					
Efficiency (AC-AC) - % (online-mode, 100% load)		>92					
Input	Nominal voltage	3-ph. 400VAC					
	Voltage range	380-400-415VAC -20% / +15%					
	Frequency	50Hz – 60Hz ± 5Hz					
	Power factor	≥0.99					
Output	Voltage	3/1ph model: 220, 230, 240 selectable / 3/3ph model: 380-415VAC selectable					
	Frequency	50Hz or 60Hz ± 0.001Hz (battery mode) ± 2Hz synchronized mains					
	Waveform	sinusoidal					
	Nominal output current at cos phi 0.9/1.0	3/1 ph	43/39A	65/58A	87/78A	-	-
		3/3 ph	15/13.5A	22/20A	29/25A	44/39A	58/52A
	THD	<2% (linear load), <5% (nonlinear load), IEC 62040-3					
Batteries	Crest factor	3:1					
	Type	Maintenance-free lead-acid batteries					
	Autonomy	starting 4 min / depending on the battery mounting					
	Nominal voltage	720VDC					
	Charging current	6A	10A	6A	10A	8A	
Switching time	AC-DC into the bypass	7-8 h to 90% of full capacity after complete discharge					
Panel	AC-DC into the bypass	0ms					
	LCD	Alpha-numeric display with backlight					
Acoustic alarm	LED	Diagram with LEDs					
	can be switched off	Yes					
Interface	RS-232 interface	Yes					
	SNMP (option)	Yes					
	Potential-free contacts (option)	Eight Signals with additional card					
Environmental	Temperature	0-40°C (batteries 0- +25°C)					
	Humidity	<95% non-condensing					
	Audible noise level (at 1m distance)	< 52dBA					
Weight	Without batteries	100kg	110kg	110kg	140kg	140kg	
	Maximum incl. internal batteries	262kg	272kg	272kg	-	-	
Dimensions	HxWxD in mm	1200 x 450 x 650	1200 x 450 x 650	1200 x 450 x 650	1200 x 450 x 650	1200 x 450 x 650	
Standards	Safety	DIN EN 62040-1					
	EMC	DIN EN 62040-2, Class C3					
	Tests	CE					
Protection		IP 20					
Color		RAL 7016					