

# Small Cases

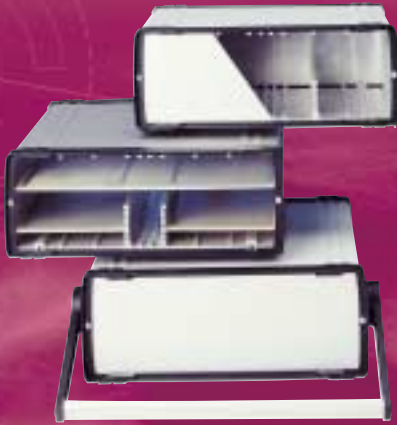

... the perfect shell for valuable electronics



**Vdream 418**  
beginning on page 7.4

- all standard-size cards (100, 120, 160, 190 to 233.35mm) can be installed in one case
- patented design
- IP 66 degree of protection



**TAREX 419**  
beginning on page 7.6

- frame colours and design can be customized
- holds Europe or double Europe cards
- IP 30 degree of protection



**PROFI CASE 415/416**  
beginning on page 7.10

- extremely functional yet simple form
- holds Europe cards and electronics
- various dimensions available
- IP 20/30 degree of protection

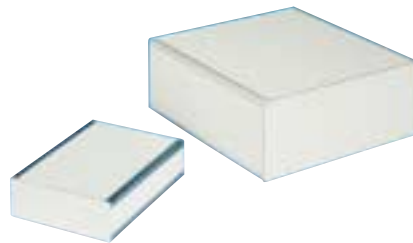

**Small frame case 414**  
page 7.14

- simple frame construction
- for Europe cards up to 220mm in depth
- IP 40 degree of protection



**Desk console 502**  
page 7.15

- simple aluminium case
- individual treatments available
- IP 30 degree of protection



### Small case 268

beginning on page 7.8

- terse, eye-catching design
- for Europe cards up to 220mm in depth
- can be used as a case for modems or external data storage media
- IP 30 degree of protection



### DIN rail case 420

page 7.16

- holds 100mm x 160mm and 100mm x 220mm PCB's
- ventilated or not ventilated
- IP 30 degree of protection

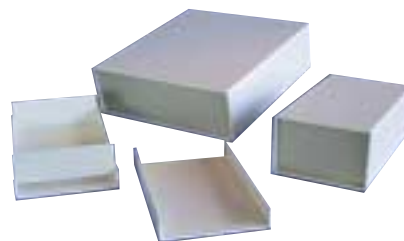

### Plastic standard case D/DB/N2U

beginning on page 7.17

- snap mechanism for assembly; no screws required
- constructed out of impact-resistant polystyrene
- IP54 degree of protection (series DD)



### Customized small case

page 7.20

- we develop the ideal small case solution based on your specific requirements



## Functionality "to the X degree"

The X-dream small case offers maximum functionality. The solid aluminium extrusion case body forms the extremely stable basis of the case.



Sample configuration

Integrated dovetail guides allow the adapter rails to be moved into different positions, which allows standard-format cards or different size electronics to be installed. This patented design creates space that has never before been available in small cases. When used with seals and front panels (see accessories), the stylish frame provides maximum protection against exterior influences (up to IP 66 degree of protection). Base feet or customized mounting equipment can be fit into the practical mounting grooves on the underside of the case.

The X-dream small case series can also be fit or retrofitted with a prop-up and carrying handle.

### *Xdream* small case

- all standard-size cards (100, 120, 160, 190 to 233.35mm) can be installed in one case
- adapter rails allow you to customize your installation
- patented design
- up to IP 66 degree of protection
- high stability
- adjustable depths
- stackable
- integrated mounting grooves
- functional accessories
- prop-up and carrying handle optional



## Specifications

### Application:

Basic case for electronics and other standard-sized cards. Adapter rails that can be positioned inside the case allow you to customize your card installation. Cards with different widths can be placed in different positions within the case.

### Construction:

solid aluminium extrusion that is enclosed by a plastic frame on the front and rear

### Finish:

RAL 7035 light grey frame, black

### Degree of protection: IP 66\*

Delivery: not assembled

Standard case for 160/120mm card depths

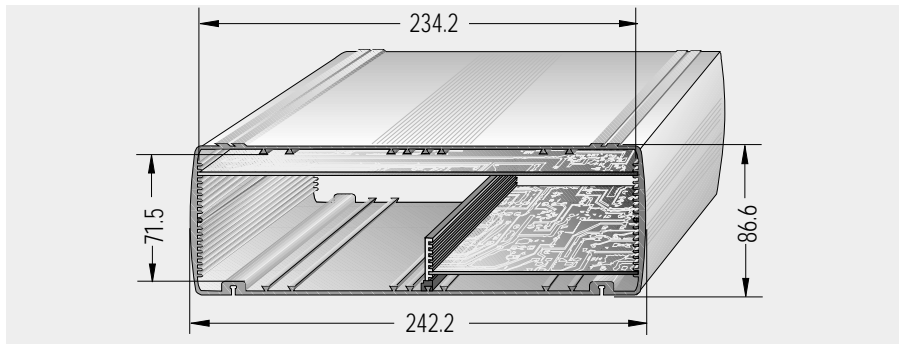
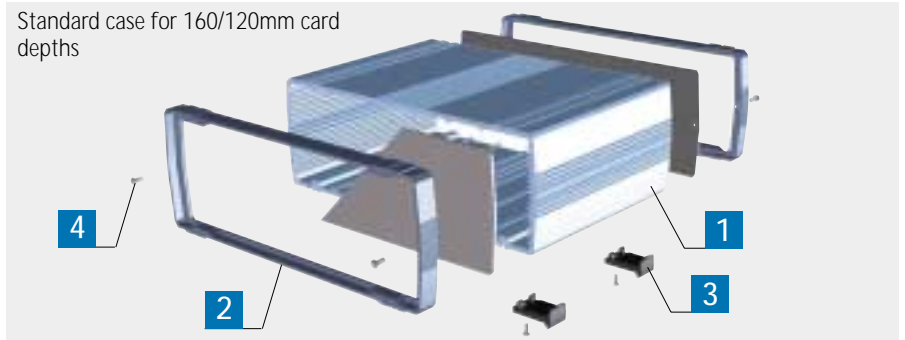

## Included in delivery

Item	Pc.	Description
1	1	Aluminium extrusion
2	2	Plastic frame
3	4	Stacking feet
4		Assembly material

## Order information

Description	for card depths d mm	Part no.
Small case, D=180mm	160	41-8001-60
Small case, D=180mm with handle	160	41-8001-65
Small case, D=240mm	220	41-8002-20
Small case, D=240mm with handle	220	41-8002-25

(\*with solid rear and front panels and frame seals, without handle)

## Accessories

### Front panel/rear panel



Material: aluminium, 2.5mm

Finish: anodized exterior side, transparent chromated interior side

Part no.
41-8004-00

### Frame seal



• self-adhesive, for adhering to front or rear panel

Part no.
41-8006-02

### Adapter rail

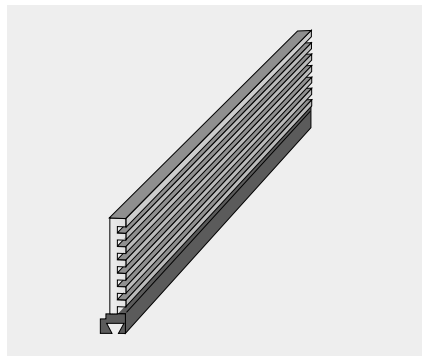

- fits in the case's dovetail guides
- with special sliding surface

Part no. for card depth d = 160mm
41-8003-16

Part no. for card depth d = 220mm
41-8003-22

### Prop-up and carrying handle



- for retrofitting
- incl. assembly material

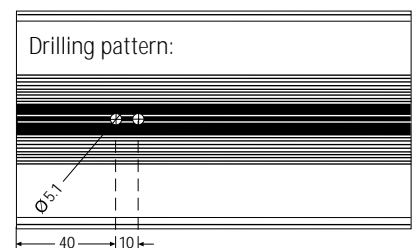

Part no.
61-5060-03



## The tailor-made enclosure

The Tarex small case allows you to implement your corporate design.

# TAREX



• Unique shape and colours



Suggested designs

### TAREX small case

- customized design according to your specifications
- reasonable price
- with or without ventilation
- IP 20/30 degree of protection

The customized enclosure frame helps your case stand out from the usual standard products. You choose the shape and colour and provide us with a drawing. We take care of the rest.



### Specifications

**Application:**

Basic case for  
2 100mm x 160mm Europe cards,  
2 double Europe cards or customized  
electronics

**Construction:**

Cover shell, chassis and front panel/  
rear panel: sheet steel

**Finish:**

RAL 7035 light grey  
Frame: black  
plastic

**Degree of protection:**

IP 20/30

**Delivery:**

not assembled

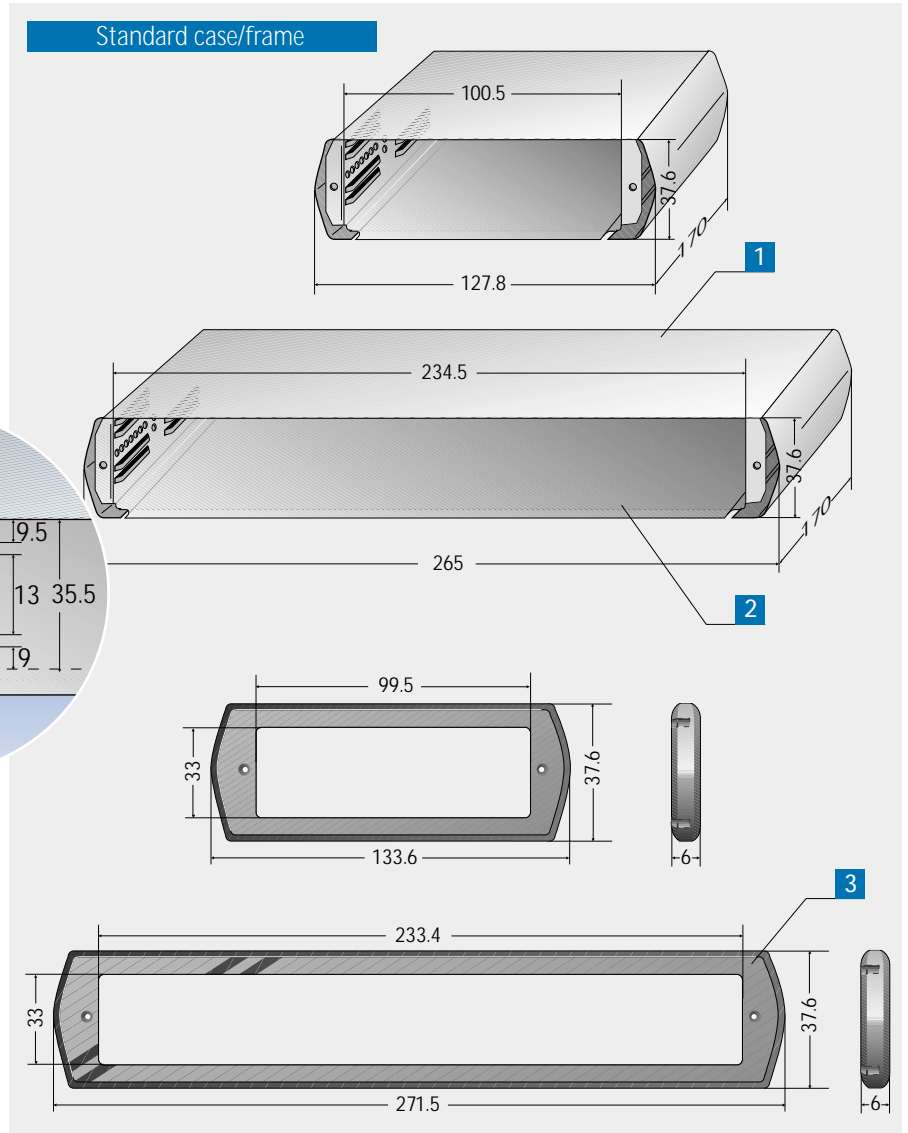
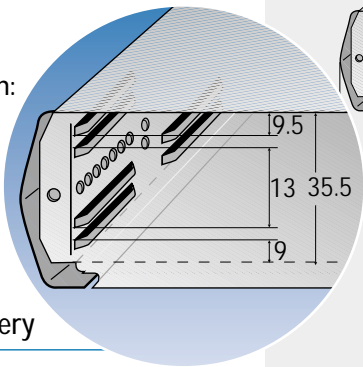

**Included in delivery**

Item	Pc.	Description
1	1	Case shell
2	1	Bottom panel
3	2	Frame
4		Assembly material

**Note:**

Order rear panel and front panels separately. Customized treatments possible.

### Order information

**Case without vents (IP 30)**

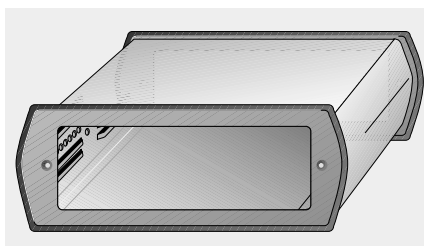

For PCB dimensions mm	Part no.
100 x 160	41-9200-00
233.35 x 160	41-9210-00

**Enclosure with vents (IP 20)**

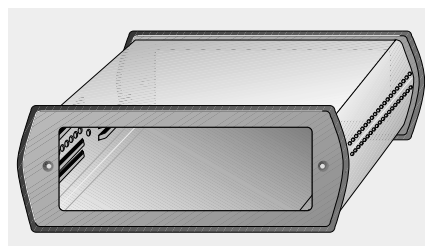

For PCB dimensions mm	Part no.
100 x 160	41-9201-00
233.35 x 160	41-9211-00

**Rear panel/front panel**

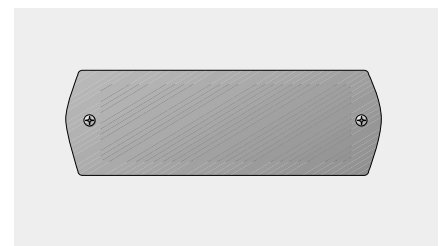

For PCB dimensions mm	Part no.
100 x 160	41-9200-10
233.35 x 160	41-9210-10



## Timeless design

The small case 268's advanced and clean design gives you a competitive advantage.

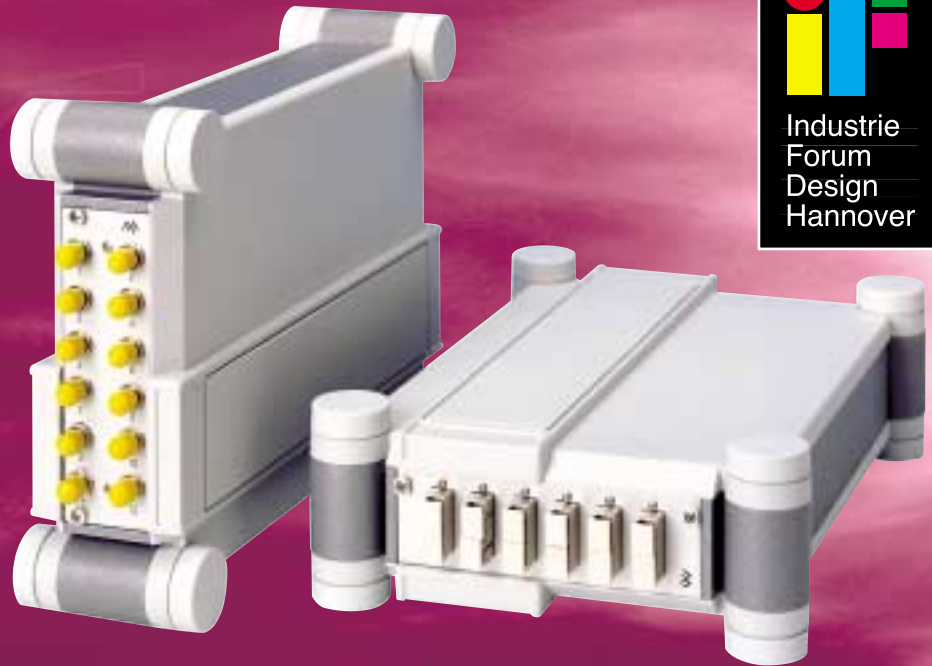

Sample configuration with network components



Sample configuration with stacking pieces

### Small case 268

- for 100mm x 160mm cards
- 100mm x 100mm cards can also be installed from the rear
- terse design
- stackable
- installation dimensions in compliance with IEC 297-3
- side cable access possible
- internal grooves allow you to attach additional components using sliding nuts
- removable plastic panel on top/bottom
- 3 stable installation options:
  - horizontal
  - vertical on the rear side
  - vertical on the side panel
- individual colours and treatments available on request
- can also be used as a LAN office cabinet (see p. 9.8)





### Specifications

**Application:**

for 100mm x 160mm and 100mm x 100mm cards and customized electronic components such as external data storage media

**Construction:**

Al extrusion side panels with plastic top/bottom pieces attached with screws

**Finish:**

Top/bottom pieces: RAL 7035 light grey  
Side sections: RAL 7032 pebble grey

**Degree of protection:**

IP 30

**Delivery:**

not assembled

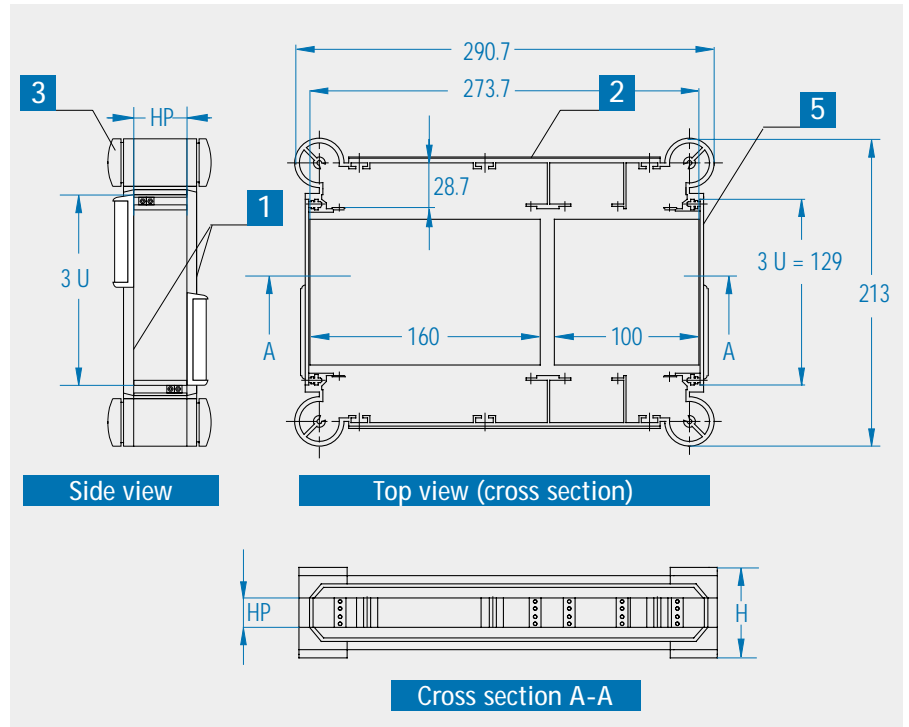

### Included in delivery

Item	Pc.	Description
1	2	Top/bottom pieces with removable plastic panel
2	2	Side extrusions
3	8	Feet
4		Assembly material

### Order information

H mm	HP		Case	Part no.	
		mm		Front panel, anodized type C with card holder 5	Front panel/rear panel, anodized type A, solid 5
62.5	4	20.1	268-004	24-3304-60	24-3304-00
67.5	5	25.1	268-005	24-3305-60	24-3305-00
72.5	6	30.2	268-006	24-3306-60	24-3306-00
77.5	7	35.2	268-007	24-3307-60	24-3307-00
83	8	40.3	268-008	24-3308-60	24-3308-00
93	10	50.4	268-010	24-3310-60	24-3310-00
103	12	60.6	268-012	24-3312-60	24-3312-00
113	14	70.8	268-014	24-3314-60	24-3314-00

Other widths (HP) available on request.

### Accessories

#### Stacking pieces

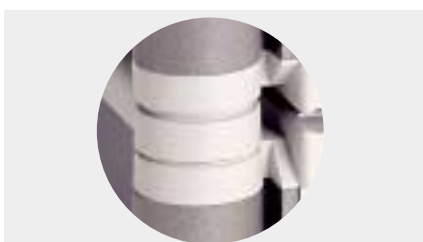

Part no.  
268-103

#### Card guides

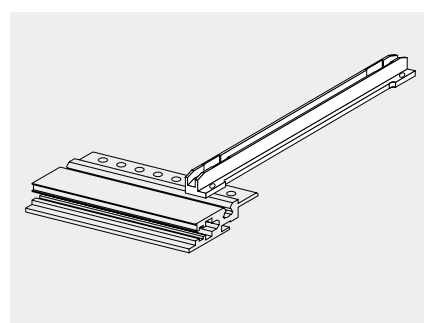

- 100mm card guide, black

Part no.  
240-402

- 160mm card guide, grey (listed according to UL 94 V-1)

Part no.  
240-401

- 160mm card guide with integrated plug-in connector fixture, black

Part no.  
240-407



## The tailor-made enclosure

The proven PROFI CASE small case series is characterized by its timeless design and simple and functional construction.

# PROFI CASE



### PROFI CASE small case

- simple construction
- short assembly time
- available with plastic side piece (series 415) or aluminium extrusion side piece (series 416)
- available as ventilated/partially ventilated or solid models
- special sizes available on request

The variety of sizes and the possibility of adding customized treatments such as special stamps or screen printing make this case ideal for a particularly wide range of applications.



### Specifications

**Application:**  
for 2 or 4 lab cards or customized electronic components

**Construction:**  
Two aluminium half shells are attached with plastic side pieces (series 415) or aluminium extrusions (series 416) and screwed together from the outside of the case.  
Integrated grooves in the side parts allow you to insert PCB's or mounting panels.

**Finish:**  
Half shells, RAL 7035 light grey  
Side parts, RAL 9005 deep black

**Degree of protection:**  
IP 40/20

**Delivery:**  
not assembled

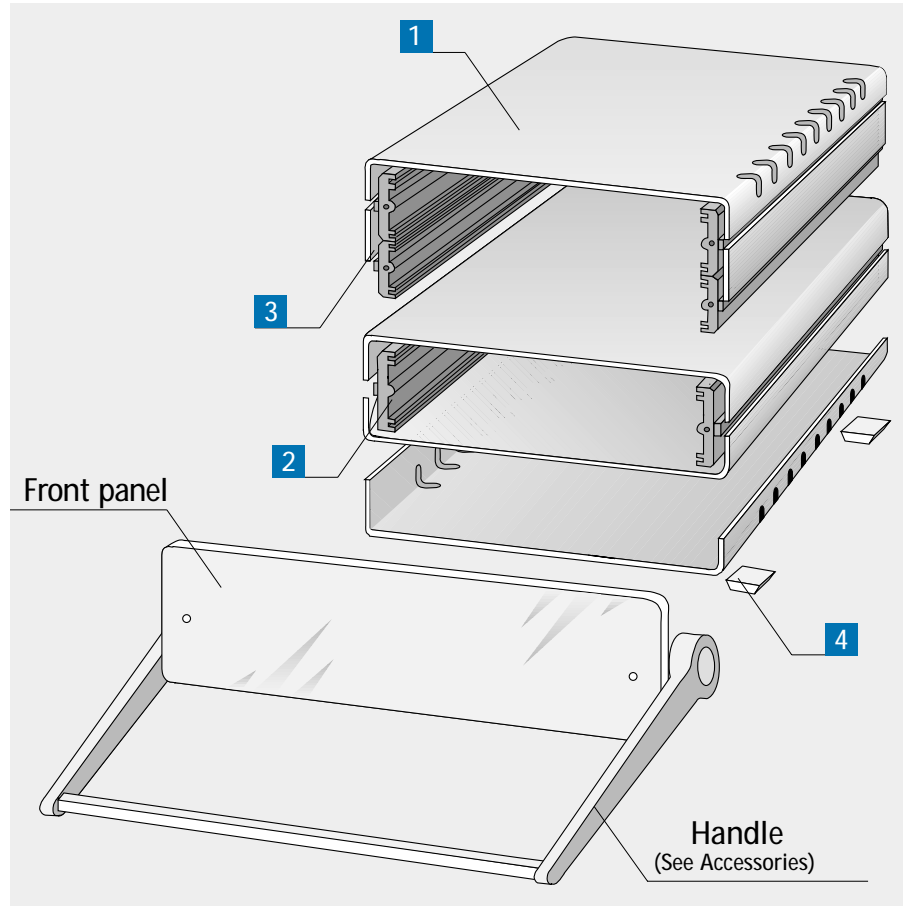

### Included in delivery

Item	Pc.	Description
1	2	Top/bottom cover
2	2	Plastic side pieces (series 415)
	4	Plastic side pieces (series 415, type 2)
	2	Aluminium extrusion side pieces (series 416)
3	2	Side panels (series 415, type 2)
4	4	Adhesive feet
5		Assembly material

**Note:**  
Order front panel, rear panel and handle separately.

#### Type 1: 415/416

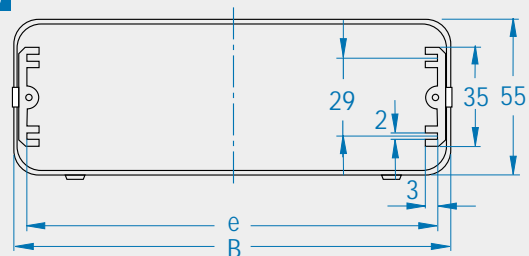

#### Type 2: 415

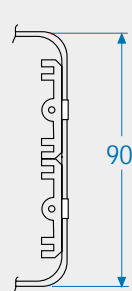

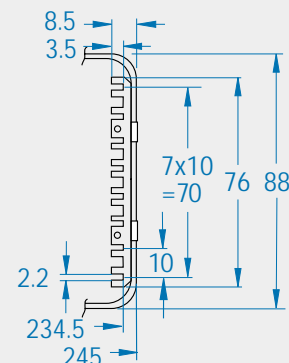

#### Type 3: 415







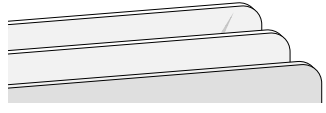

(all dimensions in mm)



Order information

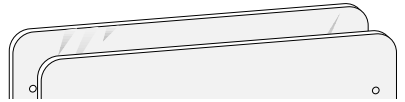

PROFI CASE 415 TYPE 1 H=55mm						Solid  One side ventilated  Both sides ventilated 			 Front panels/Rear panels		
PCB dimensions mm	Case height H mm	Case depth D mm	Avail. depth d mm	Case width W mm	Avail. width e mm	Solid IP 40	One side ventilated IP 20	Both sides ventilated IP 20	Anodized	RAL 7035	Plastic RAL 7035
100 x 160	55	175	160.5	115	101	415-303	415-323	415-343	415-103	415-123	-
120 x 160	55	175	160.5	135	121	415-305	415-325	415-345	415-105	415-125	415-165
160 x 160	55	175	160.5	175	161	415-302	415-322	415-342	415-102	415-122	-
190 x 160	55	175	160.5	205	191	415-301	415-321	415-341	415-101	415-121	415-161
233.35 x 160	55	175	160.5	248.5	234.5	415-304	415-324	415-344	415-104	415-124	-
100 x 210	55	225	210.5	115	101	415-003	415-023	415-043	-	-	-
160 x 210	55	225	210.5	175	161	415-002	415-022	415-042	-	-	-
190 x 210	55	225	210.5	205	191	415-001	415-021	415-041	-	-	-
233.35 x 210	55	225	210.5	248.5	234.5	415-004	415-024	415-044	-	-	-

PROFI CASE 415 TYPE 2 H=90mm						Solid  One side ventilated  Both sides ventilated 			 Front panels/Rear panels	
PCB dimensions mm	Case height H mm	Case depth D mm	Avail. depth d mm	Case width W mm	Avail. width e mm	Solid IP 40	One side ventilated IP 20	Both sides ventilated IP 20	Anodized	RAL 7035
100 x 160	90	175	160.5	115	101	415-313	415-333	415-353	415-113	415-133
120 x 160	90	175	160.5	135	121	415-315	415-335	415-355	415-115	415-135
160 x 160	90	175	160.5	175	161	415-312	415-332	415-352	415-112	415-132
190 x 160	90	175	160.5	205	191	415-311	415-331	415-351	415-111	415-131
233.35 x 160	90	175	160.5	248.5	234.5	415-314	415-334	415-354	415-114	415-134
100 x 210	90	225	210.5	115	101	415-013	415-033	415-053	-	-
160 x 210	90	225	210.5	175	161	415-012	415-032	415-052	-	-
190 x 210	90	225	210.5	205	191	415-011	415-031	415-051	-	-
233.35 x 210	90	225	210.5	248.5	234.5	415-014	415-034	415-054	-	-

PROFI CASE 415 TYPE 3						 Front panels/Rear panels				
PCB dimensions mm	Case height H mm	Case depth D mm	Avail. depth d mm	Case width W mm	Avail. width e mm			Anodized	RAL 7035	RAL 7035 ventilated
233.35 x 160	88	280	273	245	234.5	415-504	415-505	415-604	415-624	415-634



Order information

PROFI CASE 416 H=55mm						 One side ventilated  Both sides ventilated		 Front panels/Rear panels	
PCB dimensions mm	Case height H mm	Case depth D mm	Avail. depth d mm	Case width W mm	Avail. width e mm	One side ventilated IP 20	Both sides ventilated IP 20	Anodized	RAL 7035
100 x 160	55	175	160.5	115	101	416-303	416-323	415-103	415-123
120 x 160	55	175	160.5	-	-	-	-	-	-
160 x 160	55	175	160.5	175	161	416-302	416-322	415-102	415-122
190 x 160	55	175	160.5	205	191	416-301	416-321	415-101	415-121
233.35 x 160	55	175	160.5	-	-	-	-	-	-
100 x 210	55	225	210.5	115	101	416-003	416-023	-	-
160 x 210	55	225	210.5	175	161	416-002	416-022	-	-
190 x 210	55	225	210.5	205	191	416-001	416-021	-	-
233.35 x 210	55	225	210.5	-	-	-	-	-	-

Accessories

Prop-up and carrying handle



- consists of handle brackets and a handle piece, which can be cut to the appropriate length
- handle can be set 30° by pressing a button to snap it into place
- attached by a single hole on both sides

Material:

Handle extrusion: anodized aluminium  
 Handle brackets: black polyamide

Carrying capacity:

25kg

Determine the length of the handle section you need using the following formula:

$$\text{Handle section length (L)} = \text{case width (W)} + 16\text{mm}$$

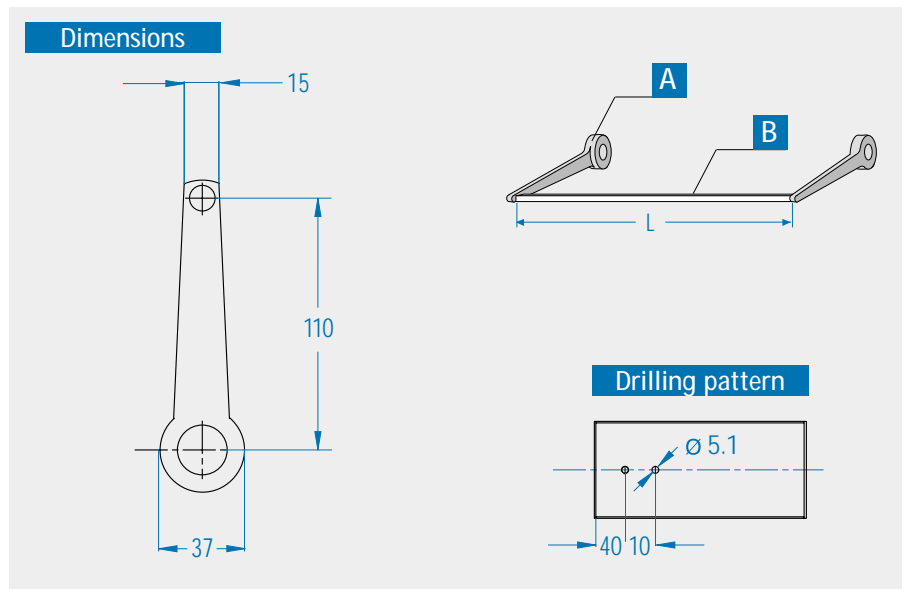

**A** Handle brackets

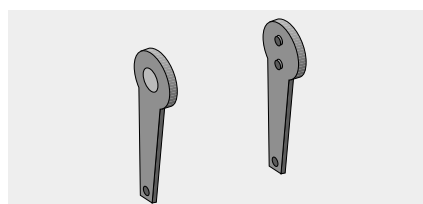

Part no. (pair)  
615-060

**B** Handle section

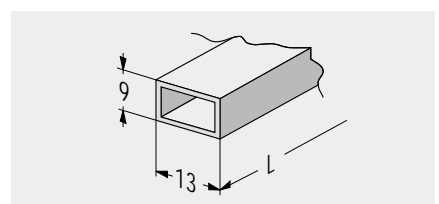

- 1m piece to cut to appropriate length

Part no. (1m)  
615-061



## 414 • Small frame case



This simply constructed case consists of 4 aluminium edge pieces, 4 facing panels and 2 top panels. The aluminium extrusions have grooves for holding 2 Europe cards.

The front/rear panels can be pre-punched for plug or cable entry depending on your specifications.

### Small frame case

- cost-effective
- variable width/height/depth

#### Application:

for 2 lab cards or customized electronic components

#### Finish:

Front/rear panel and sections:  
anodized aluminium  
Cover panels  
RAL 7035 light grey

#### Degree of protection:

IP 40

#### Delivery:

not assembled

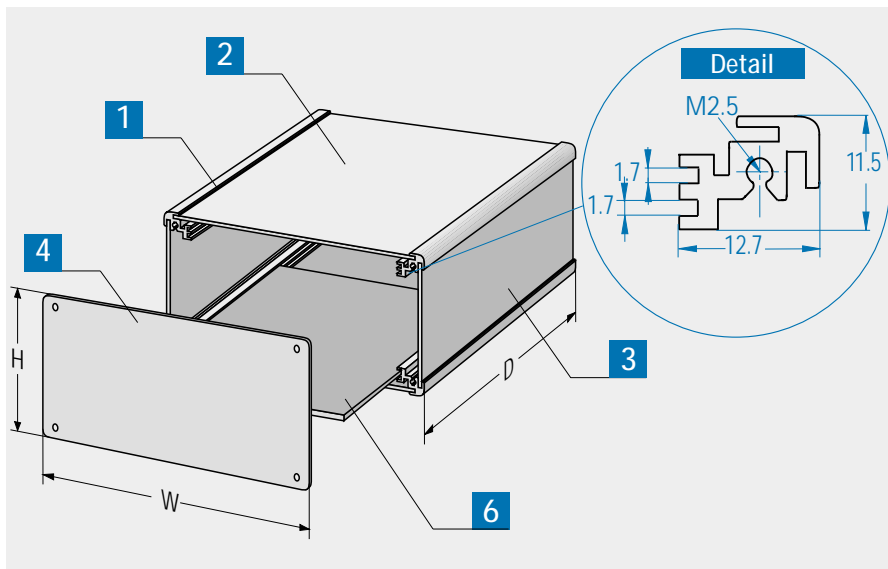

### Included in delivery

Item	Pc.	Description
1	4	Extrusions
2	2	Cover panel 1
3	2	Cover panel 2
4	2	Front/rear panels
5		Assembly material

#### Note:

Order chassis panel separately.

### Order information for case and chassis panel

Dimensions		Case		Chassis panel <b>6</b>	
W mm	H mm	D = 166.6mm effective installation dim. w x d = 197.8 x 162.6mm	D = 226.6mm effective installation dim. w x d = 197.8 x 222.6mm	For cases D = 166.6mm	For cases D = 226.6mm
220	44	414-101	414-111	414-151	414-161
220	88	414-103	414-113	414-151	414-161

### Order information for case and chassis panel, fits 100mm x 160mm and 100mm x 220mm Europe cards

Dimensions		Case		Chassis panel <b>6</b>	
W mm	H mm	D = 166.6mm for 100 x 160 cards	D = 226.6mm for 100 x 220 cards	For cases D = 166.6mm	For cases D = 226.6mm
122.2	44	414-105	414-115	414-153	414-163
122.2	88	414-106	414-116		



### Desk console

- desk console in light aluminium construction
- bottom piece with sides folded upwards
- hood fits inside bottom piece and is screwed together from underneath



### Specifications

**Application:**

for controls  
such as keyboards

**Material:**

aluminium panel, 2mm

**Finish:**

RAL 7035 light grey

**Delivery:**

not assembled

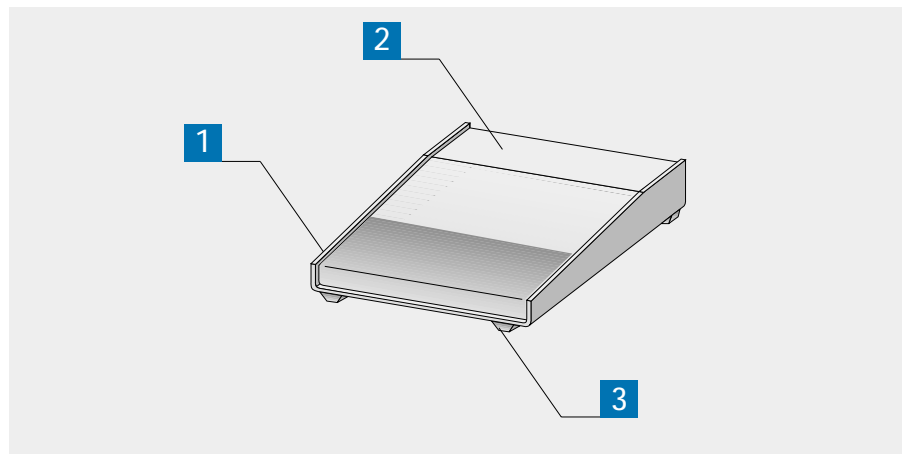

### Included in delivery

Item	Pc.	Description
1	1	Bottom shell
2	1	Cover hood
3	4	Case feet, self-adhesive
4		Assembly material

**Note:**

Additional sizes and customized treatments (for example, screen printing) available on request.

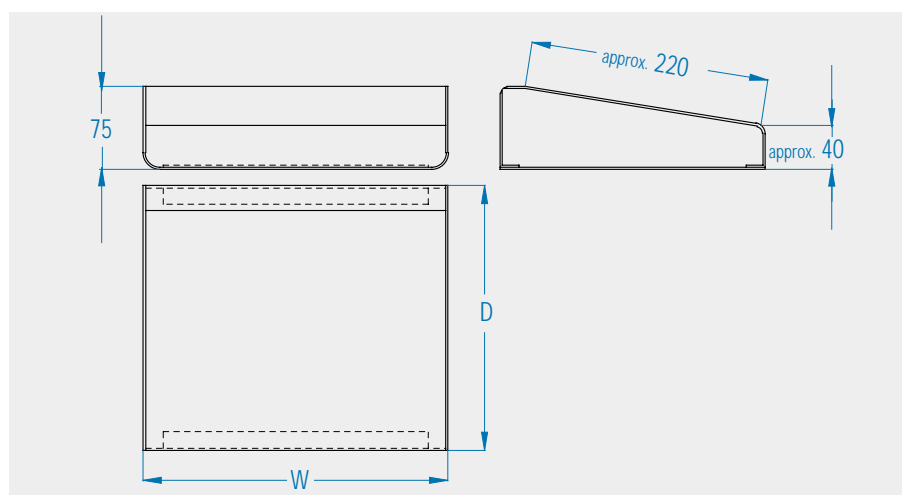

### Order information

W mm	Part no.		
	D = 240mm	D = 340mm	D = 540mm
490	502-001	502-002	502-003
420	502-011	502-012	-
276	502-021	-	-



## 420 • DIN rail case

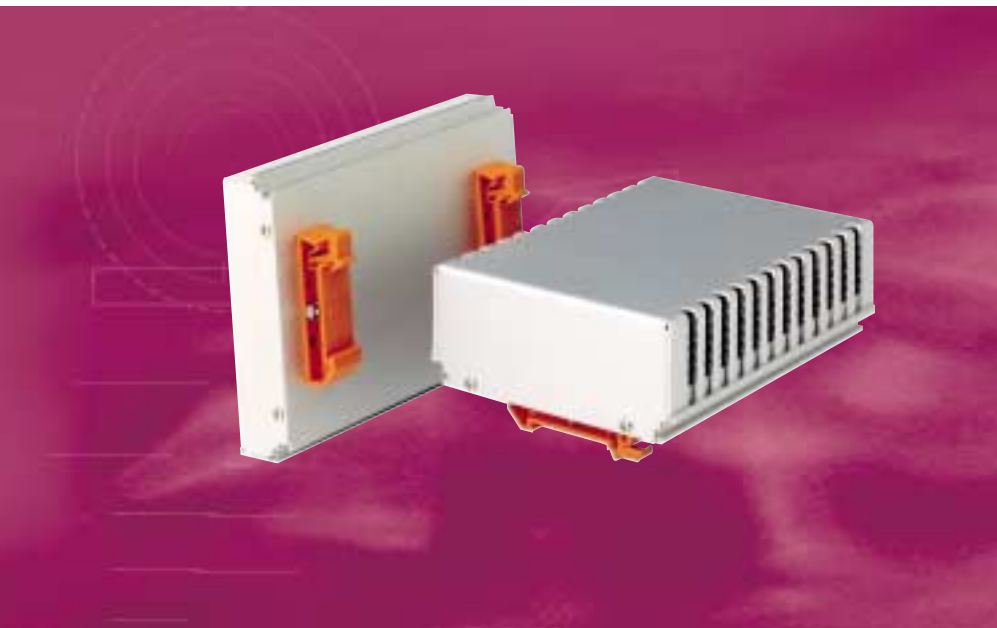

### DIN rail case

- stable and convenient clip device for mounting on DIN rails
- easy assembly
- cost-effective

#### Application:

for 100mm x 160mm and  
100mm x 220mm Europe cards

#### Construction:

Aluminium extrusion rear panel,  
aluminium panel cover shells  
and PA 6 plastic DIN rail clips

#### Finish:

RAL 7035 light grey  
transparent chromated interior

#### Degree of protection:

IP 30

#### Delivery:

not assembled

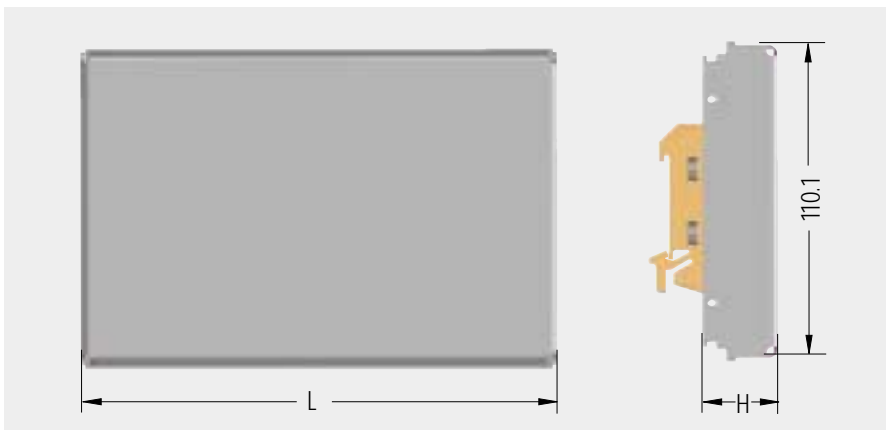

### Order information

Length L mm	Height H mm	PCB size mm	Part no.
163.5	26	100 x 160	42-0001-00
223.5	26	100 x 220	42-0001-10
163.5	46	100 x 160	42-0002-00
223.5	46	100 x 220	42-0002-10

### Included in delivery

Item	Pc.	Description
1	1	Cover shell
2	1	Rear panel
3	2	DIN rail clips
4		Assembly material

### Accessories

#### DIN rail

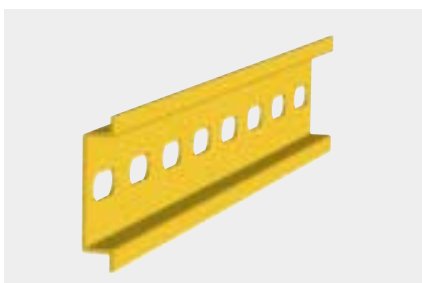

**Material:**  
steel, galvanized

Type	Length mm	Part no.
NS 35 7.5	200	64-0236-02
NS 35 7.5	600	64-0236-08

#### DIN rail clip



Part no.
442-311





## Series D standard case

- plastic case constructed from impact-resistant polystyrene, 3mm
- connected by snap locks; no screws required
- easy assembly

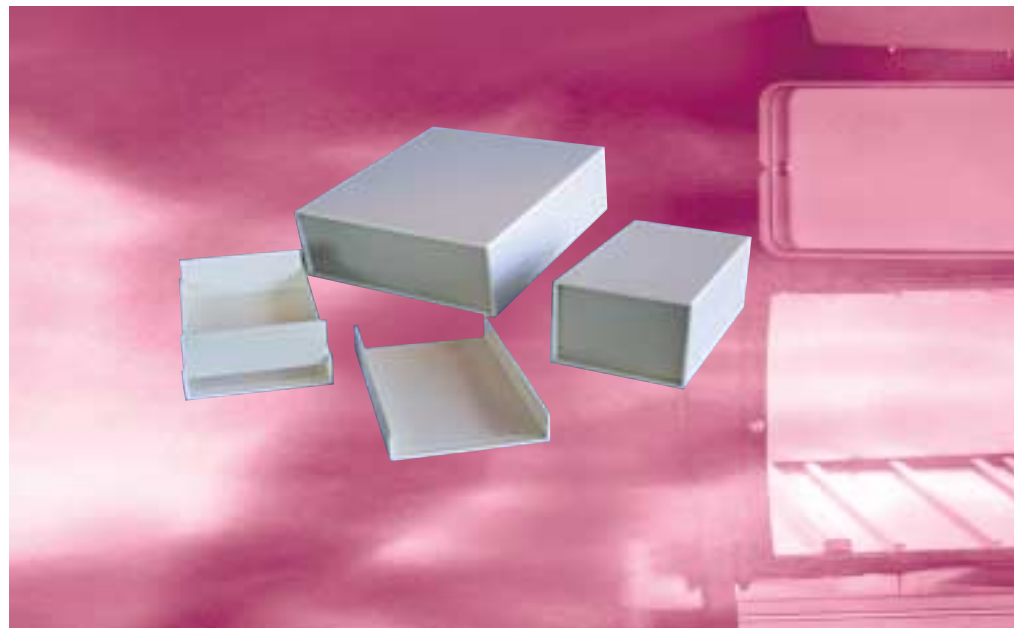

## Specifications

### Application:

case for boards or small modules

### Material:

polystyrene, 3mm

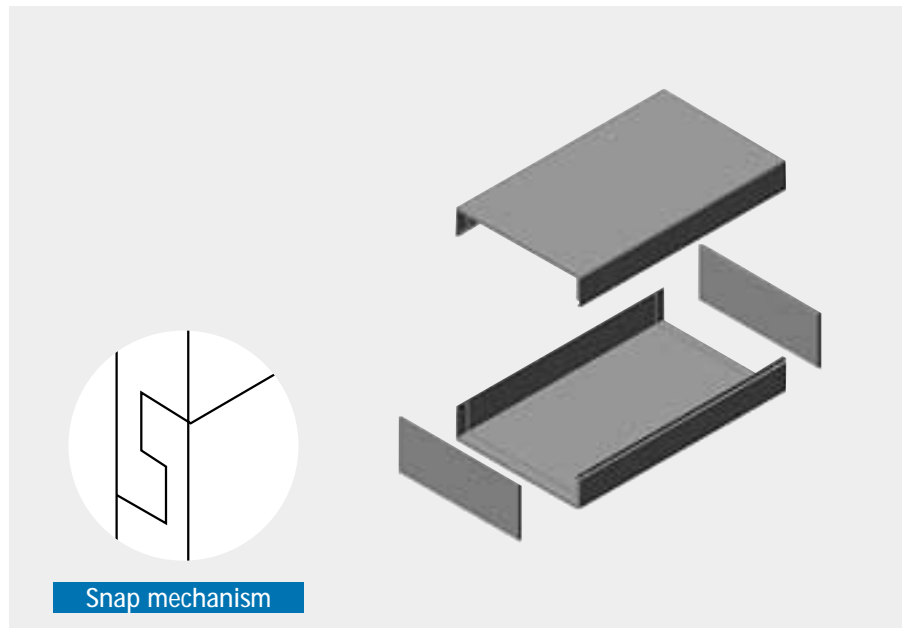

## Included in delivery

Item	Pc.	Description
1	1	Top shell
2	1	Bottom shell
3	2	Front panels
4	2	Card guides

## Order information

Description Part no.	Interior dimensions			Colour
	H mm	W mm	D mm	
D 10	50	100	110	grey-white/warm grey
D 20	35	145	170	grey-white/warm grey
D 25 R	40	103	160	grey-white/warm grey
D 30	40	120	170	grey-white/warm grey
D 40	70	110	145	grey-white/warm grey
D 45 R	70	103	160	grey-white/warm grey
D 50	60	160	170	grey-white/warm grey
D 60	100	180	210	grey-white/warm grey
D 70	70	200	215	grey-white/warm grey



## Plastic standard case DB

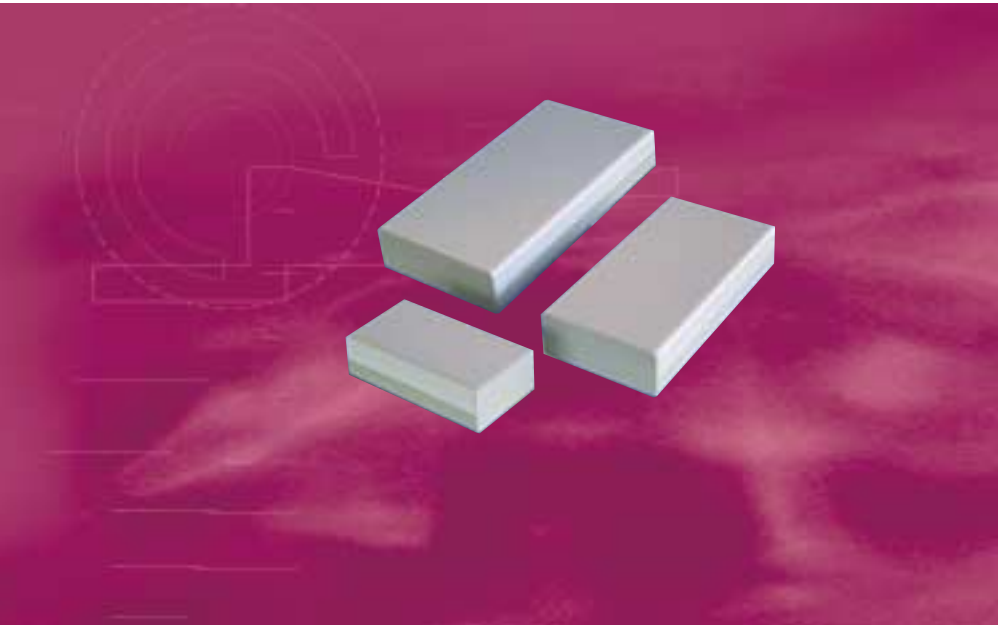

### Series DB standard case

- plastic case constructed from impact-resistant polystyrene, 3mm
- connected by snap locks; no screws required
- 2 card guides can be glued in

**Degree of protection:**  
IP 54

### Specifications

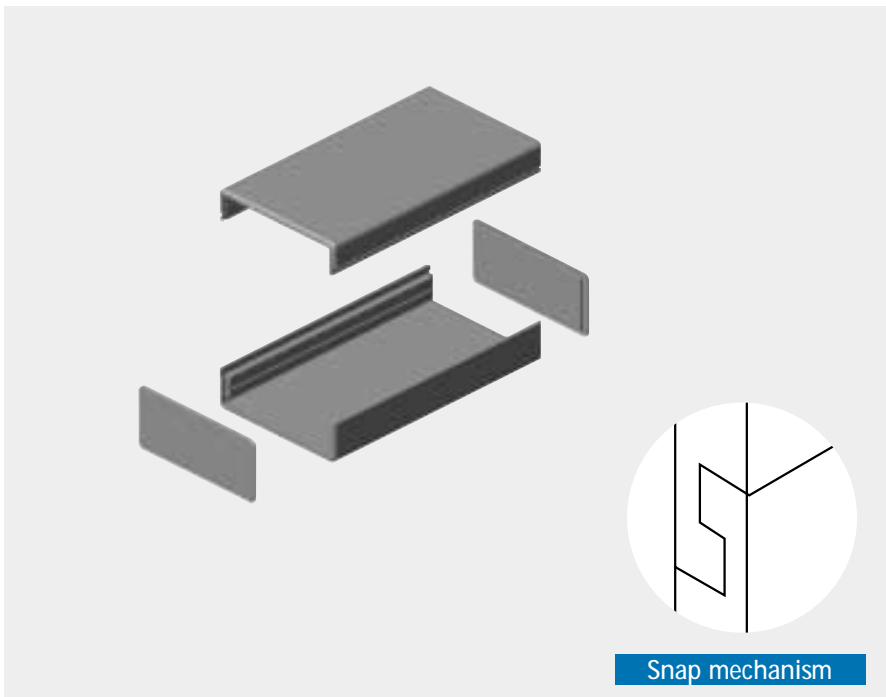

### Application:

case for boards or small modules

### Material:

polystyrene, 3mm

### Order information

Description Part no.	Interior dimensions			Colour
	H mm	W mm	D mm	
DB 1	25	53	103	grey-white/warm grey
DB 2	25	63	125	grey-white/warm grey
DB 3	30	83	163	grey-white/warm grey
DB 4	30	103	203	grey-white/warm grey
DB 5	50	103	203	grey-white/warm grey
DB 6*	17	38	83	grey-white/warm grey

### Included in delivery

Item	Pc.	Description
1	1	Top shell
2	1	Bottom shell
3	2	Front panels
4	2	Card guides, can be glued in



## Series N2U standard case

- plastic case constructed from impact-resistant polystyrene, 3mm
- locks together with tongue and groove joints
- U-shaped top and bottom pieces
- no screws required

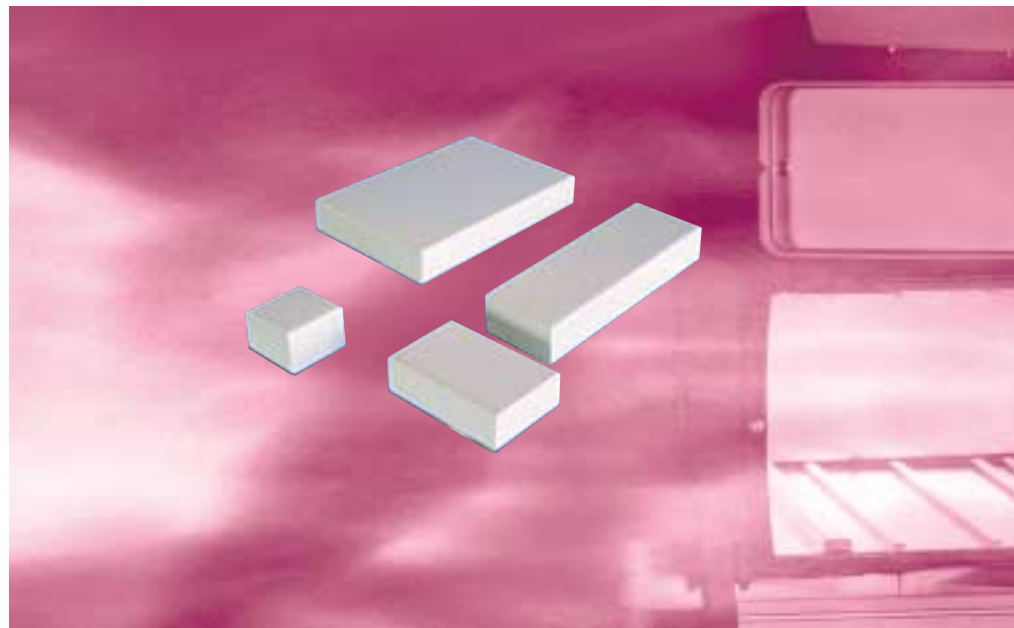

## Specifications

### Application:

case for boards or small modules

### Material:

polystyrene, 3mm

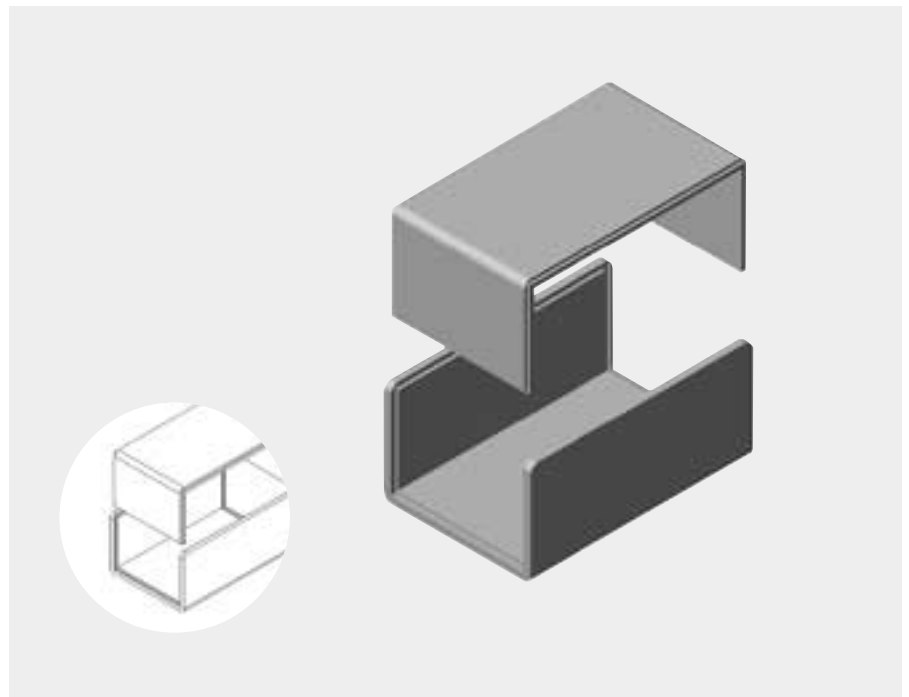

## Included in delivery

Item	Pc.	Description
1	1	Top shell
2	1	Bottom shell

## Order information

Description Part no.	Interior dimensions			Colour
	H mm	W mm	D mm	
N2U 1	25	40	40	grey-white
N2U 2	20	90	35	grey-white
N2U 3	25	53	163	grey-white
N2U 4	20	53	83	grey-white
N2U 5	35	53	83	grey-white
N2U 6	20	103	163	grey-white
N2U 7	20	163	203	grey-white



## Visions become reality ...



Customized small case

- special 19" apraTEK 180 model
- sheet steel design with locking front door
- integrated cable access openings



Customized small case

- series 416 models
- with new shapes and colours

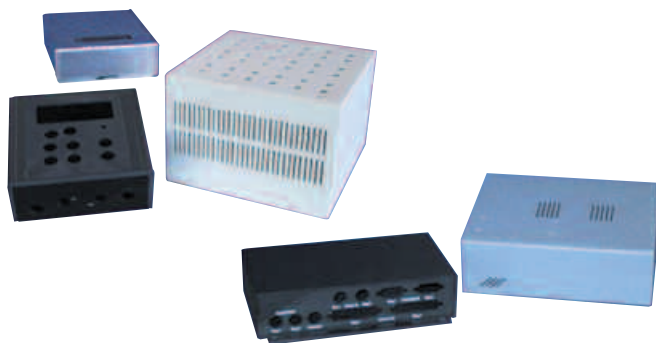

Plastic case

- customized plastic case, milling and bending technology (manufactured by apra-plast)



Shell case

- two-piece aluminium shell case, manufactured and shipped within 24 hours!