

LAN Office Workstation System



... the perfect shell for valuable electronics



LAN Office Workstation System

Ergonomic workstations

LAN Office is apra-norm's convincing solution for workplace ergonomics and offers customized solutions for your special requirements.



Features



Optimized cable management
invisible from the front
direct access from the rear



Well constructed additional components
under-desk keyboard trays
and much more



Modules
enables installation of
19" elements

LAN Office workstation system

- 2 colour combinations available
- integrated cable entry
- optional 19" modules
- a variety of accessories (shelves, etc.)

Material:

Rack: sheet steel
Desktop: "E1" particle board with HPL plastic coating

Finish:

Desktop and shelves:
RAL 7035 light grey
Vertical mountings:
pigeon blue RAL 5014
(RAL 7037 dust grey)

Delivery:

not assembled, incl. assembly instructions



Your direct line to us
Tel. + 49 65 92 | 95 12-0

Shelves

- can be used as horizontal shelves
- can be used as a tray
(can be mounted at different angles)
- as surface for equipment, etc.





585 • LAN Office workstation system

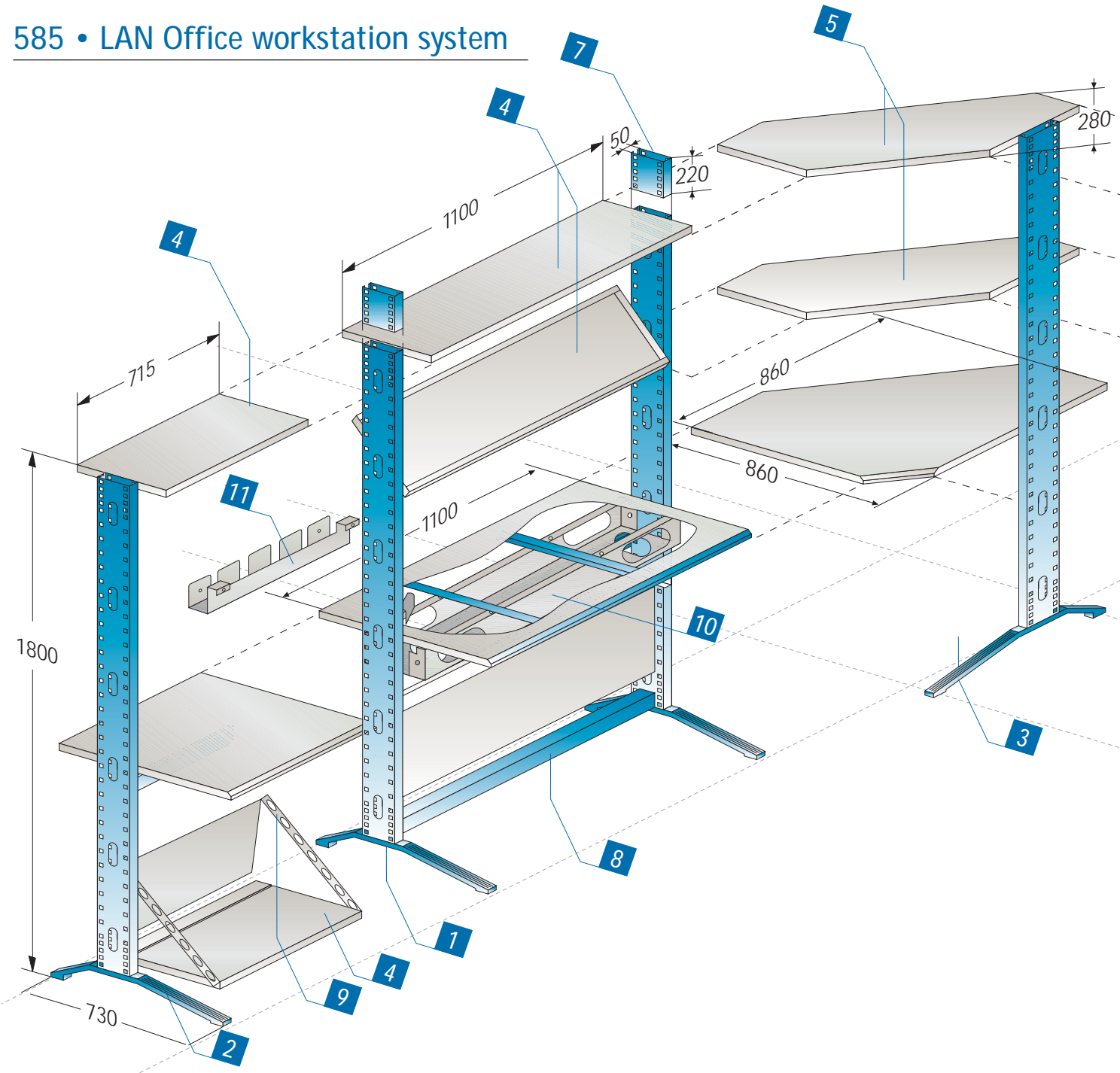

Delivery:
not assembled, incl. assembly instructions

Colour combination I:

Desktop and shelves:
RAL 7035 light grey
Vertical mountings:
pigeon blue RAL 5014

Colour combination II:

Desktop and shelves: RAL 7035 light grey
Vertical mountings: RAL 7037 dust grey

Delivery of basic rack

Item	Pc.	Description
1	2	Vertical mounting with feet
2	1	Desktop, 800mm deep
3	2	Shelves, 400mm deep
4	1	Shelf, lower mounted vertically
5	1	Cable duct under the desktop
6	1	Cable duct, hanging
7		Assembly material

Delivery of additional racks

Item	Pc.	Description
1	1	Vertical mounting with foot
2	1	Desktop, 800mm deep
3	2	Shelves, 400mm deep
4	1	Shelf, lower mounted vertically (not in corner combination)
5	1	Cable duct under the desktop
6	1	Cable duct, hanging
7		Assembly material

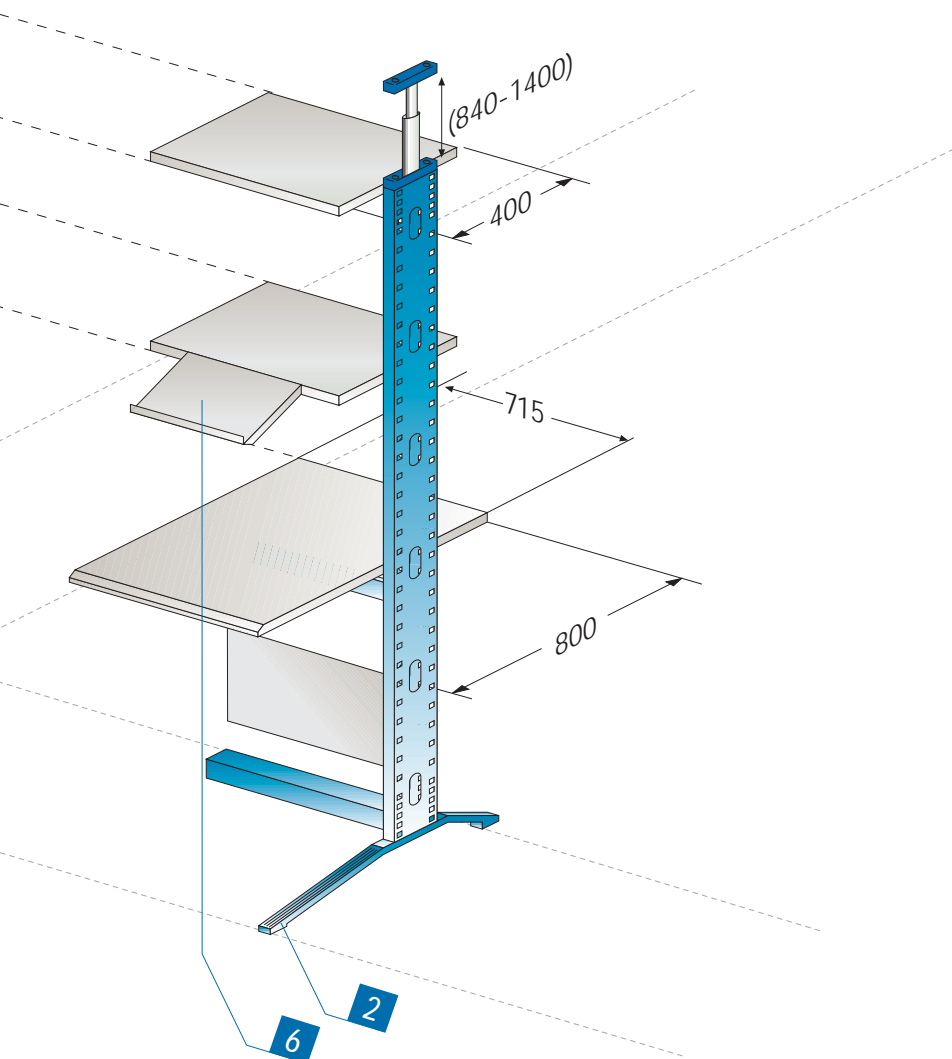

Item	Description	Page
1	Basic rack	10.5
2	Additional rack	10.5
3	Corner rack	10.5
4	Shelves	10.6
5	Shelves Corner rack	10.6
6	Keyboard shelf, hanging	10.6
7	Shelf attachment	10.6
8	Feet support	10.6
9	Mounting panel for shelf	10.6
10	Cable duct under the desktop (included in delivery)	
11	Cable duct, hanging (included in delivery)	

1 LAN Office basic rack

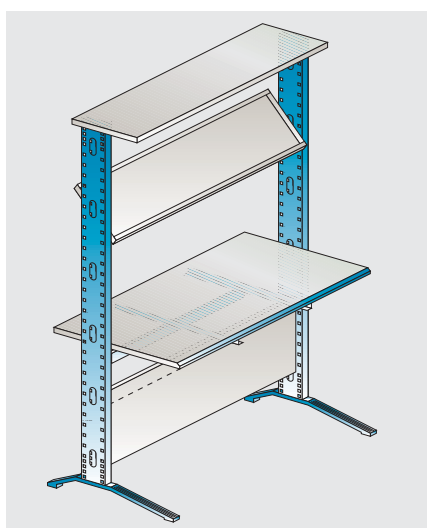

Description (H x W x D)	Part no. Colour I	Part no. Colour II
1800x1200x800	58-5001-00	58-5001-50
1800x 815x800	58-5002-00	58-5002-50

2 LAN Office additional rack

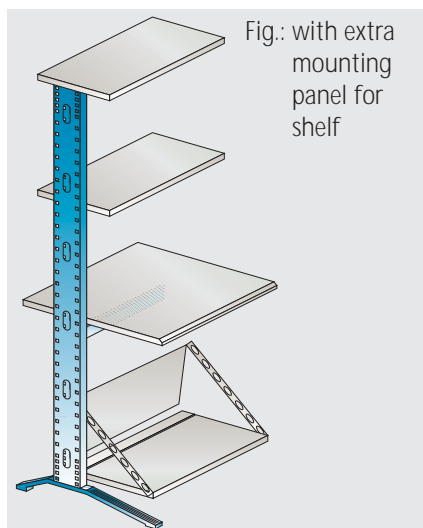

Description (H x W x D)	Part no. Colour I	Part no. Colour II
1800x1150x800	58-5003-00	58-5003-50
1800x 765x800	58-5004-00	58-5004-50

3 LAN Office corner rack

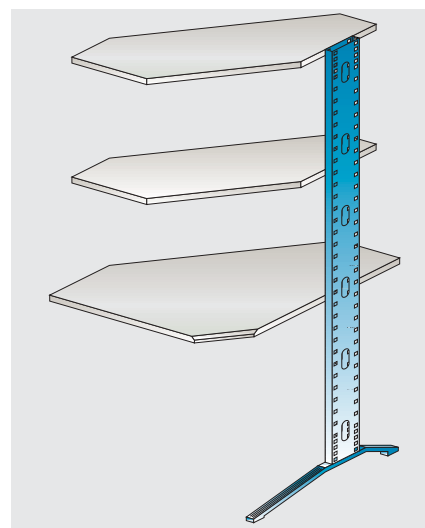

Description H mm	Part no. Colour I	Part no. Colour II
1800	58-5005-00	58-5005-50



585 • LAN Office workstation system



Accessories

Shelves:

LAN Office shelves are extremely versatile. They can be installed horizontally and at different angles. For example, the foot area can be covered by installing a shelf vertically towards the rear.

You can also mount shelves flush with the desktop to hold towers or other equipment.

Included in accessories delivery:

incl. assembly material

Finish:

Shelves: RAL 7035 light grey

4 Shelf

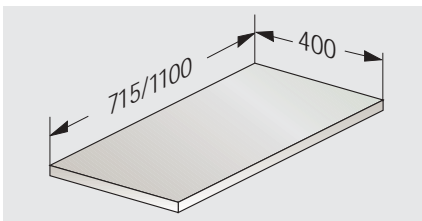

Description mm	Part no.
for W= 1200/1150	58-5001-10
for W= 815/765	58-5002-10

5 Shelf for corner rack

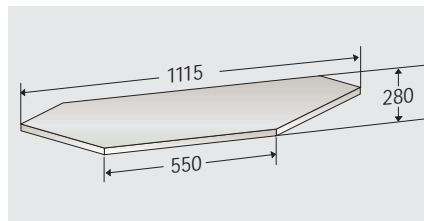

Part no.
58-5005-10

6 Keyboard shelf, hanging

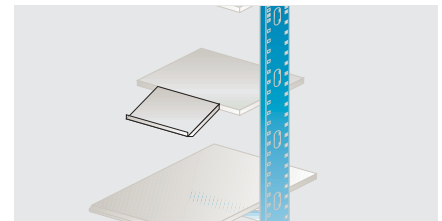

Part no.
58-5001-12

Keyboard tray



Description	Part no.
Without keyboard	20-2870-70
With keyboard	20-2870-80

7 Shelf attachment

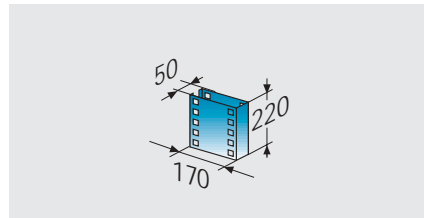

Part no.
58-5001-17

8 Feet support for W=1200mm

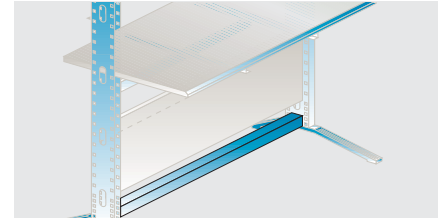

Part no.
58-5001-16

9 Mounting panel for shelf

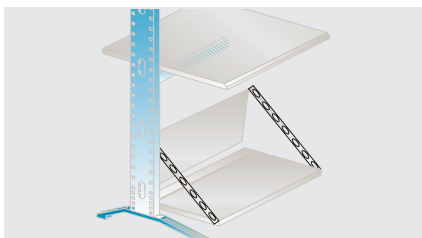

Part no. (1 piece)
58-50001-14

19" module for 4 U

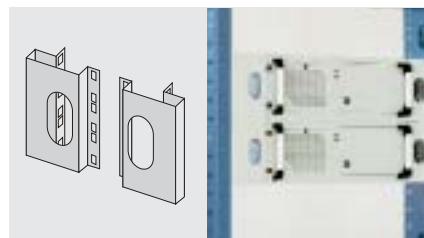

Part no.
58-5002-12

Ceiling support

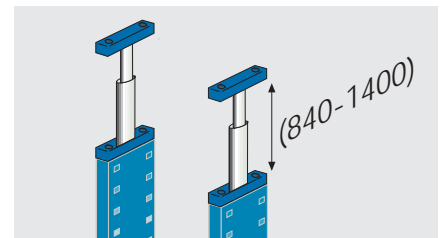

- for stabilizing the LAN Office rack against the ceiling
- the ceiling support is telescoping and can bridge distances from 840mm to 1400mm (max. clearance 3200mm)

Sliding rails for 19" modules

- for heavy 19" plug-in units

Part no. (pair)
58-5002-14

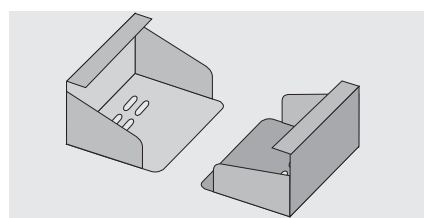

Part no. (pair)
58-5001-35